

EVENT <i>PHS</i>	GO-ROUND	DATE <i>10/8/11</i>	JUDGE <i>Ted Robinson</i>
CLASS <i>2. step</i>	NATIONAL REINED COW HORSE ASSOCIATION		



**REINED WORK JUDGES CARD**

- 1/2 POINT PENALTIES**  
 Not changing leads simultaneously Over or under spin 1/8 turn  
 Jogging first two strides
- 1 POINT PENALTIES**  
 Out of lead Out of lead each 1/4 circle  
 Slipping rein in the bridle Scotching or anticipating stop  
 Over or under spin 1/4 turn Excessive whipping or spurring
- 2 POINT PENALTIES**  
 Lead missed around end of arena past second corner  
 Not ever changing leads in patterns where there is only 1/2 circle  
 Failure to run by marker before stop is initiated  
 Freezing up in turn  
 Breaking gait  
 Jogging beyond two strides  
 On trot in patterns, failure to stop before executing a lope departure  
 A stop in the first 1/4 of the circle, after a lope departure, is a break of gait
- 5 POINT PENALTIES**  
 Spurring or hitting in front of cinch at anytime  
 Blatant disobedience including kicking, biting, bucking, rearing, and striking or obviously insubordinate

- 0- SCORE**  
 Not following pattern (i.e. over or under spin more than 1/4)  
 Two hands on the reins in a bridle or two-rein class  
 Fingers between the reins in a bridle class, except the two-rein class.  
 Horse balking  
 Bloody mouth (inside)  
 Illegal equipment  
 Leaving working area before pattern is complete  
 Fall of horse or rider  
 Backing more than 2 strides when no back up is called for in the pattern  
 Jogging in excess of one-half circle or one-half the length of the arena
- NE** - Failure of an exhibitor to attempt to complete the pattern

MANEUVER SCORES: -1 1/2 Extremely Poor, -1 Very Poor, -1/2 Poor, 0 Correct, +1/2 Good, +1 Very Good, +1 1/2 Excellent

#	HORSE	MANEUVER DESCRIPTION	MANEUVER SCORES							PENALTY TOTAL	SCORE
			LC	LS	RC	RS	RRB	STOP BACK			
	150		1	2	3	4	5	6	7		
		PENALTY						1/2			
		SCORE	0	-1/2	0	-1/2	-1/2	-1		1/2	66 1/2
	162										
		PENALTY									
		SCORE	0	0	0	0	-1/2	-1/2			69
	168						Obstruction				
		PENALTY									
		SCORE	0	0	0		-1	-1			0
	174						1/2				
		PENALTY									
		SCORE	0	-1/2	0	1/2					0
		PENALTY									
		SCORE									
		PENALTY									
		SCORE									
		PENALTY									
		SCORE									
		PENALTY									
		SCORE									
		PENALTY									
		SCORE									

JUDGES SIGNATURE *Ted Robinson*







## Reining

**NRHA Pattern #10**

1. Run past the center marker and do a sliding stop. Back up to the center of the arena or at least ten feet (three meters). Hesitate.

2. Complete four spins to the right. Hesitate.

3. Complete four and one-quarter spins to the left so that the horse is facing the left wall or fence. Hesitate.

4. Beginning on the right lead, complete three circles to the right: the first two circles large and fast, the third circle small and slow. Change leads at the center of the arena.

5. Complete three circles to the left: the first circle small and slow, the next two circles large and fast. Change leads at the center of the arena.

6. Begin a large fast circle to the right but do not close this circle. Run down the right side of the arena past the center marker and do a left rollback at least twenty feet (six meters) from the wall or fence - no hesitation.

7. Continue back around the previous circle but do not close this circle. Run down the left side of the arena past the center and do a right rollback at least twenty feet (six meters) from the wall or fence - no hesitation.

8. Continue back around previous circle but do not close this circle. Run down the right side of the arena past the center marker and do a sliding stop at least twenty feet (six meters) from the wall or fence. Hesitate to demonstrate completion of the pattern.

Rider must dismount and drop the bridle to the designated judge.

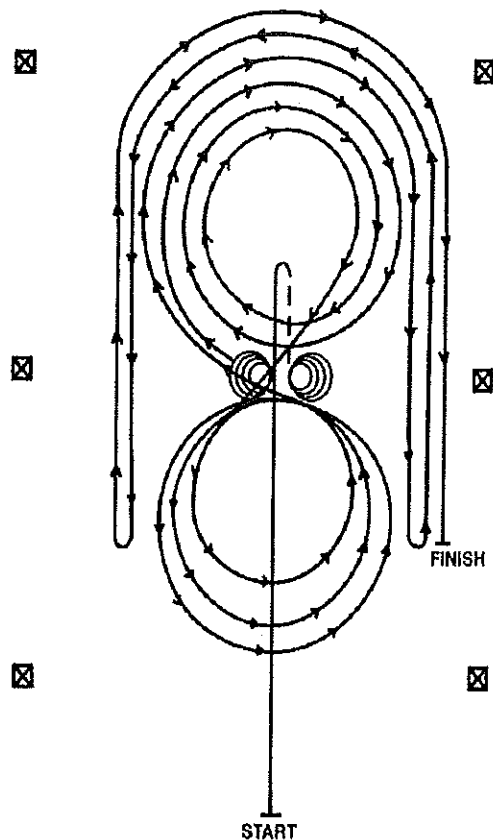

Greener Than Grass - 1 spin to right  
 1/4 spin to left  
 Simple lead change okay